

FLAVIA GR61

- colors: structure
 black stainless steel
- colors: lateral
 beige wood (others on request)
- 



FLAVIA GR61

Professional coffee machine with GR61 visible dispensing groups, available with mechanical lever dispensing or with programmable coffee doses.

Technical Features

- Available in automatic version (DG) with volumetric dose . or with lever (LT control)
- Thermosiphonic system with GR61 groups
- BMS boiler management system
- PID thermal control system
- Dose and temperature setting from the display (DG)
- 1 lever-operated steam wand
- 1 lever-operated mixed hot water wand
- Push-buttons keyboard and display (DG) - lever (LT)
- Dual-scale water pressure gauge
- Raised groups with adjustable cup support grid
- Stainless steel and aluminum bodywork

Available Versions

- Automatic 1GR and 2GR
- Lever 1GR and 2GR

Optionals

- Cup warmer
- Side panel LED lighting
- Capsules | pod group kit
- Coffee dispensing counter
- Cloud connection



Groups Height
70 | 110 mm

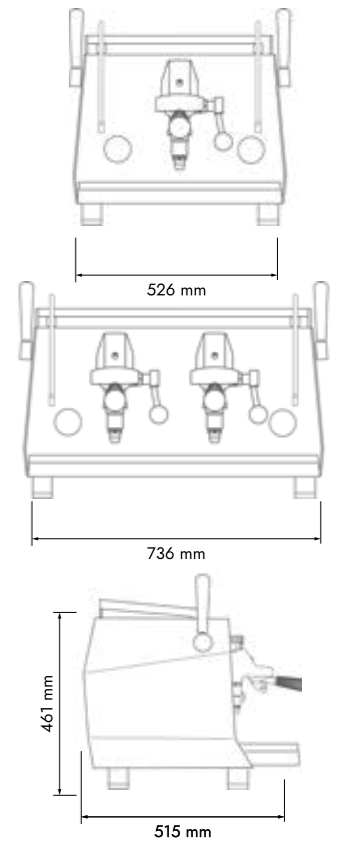

Groups	Model	Control	Electric Heater	Voltage	Boiler	Weight
1	FLAVIA	DG/LT	2.640 W	220-240V 380-415 V (3N)	5 L	43 Kg
2	FLAVIA	DG/LT	4.660 W	220-240V 380-415 V (3N)	8 L	56 Kg

