

TUBE

COLORS: Black | White | Red | Orange | Yellow | Green | Blue

Filter paper pod coffee machine can be used both at home and in the office.

TECHNICAL FEATURES

- Pods coffee machine for 44mm and 38mm diameter
- Patented Compensator
- The automatic version is available with two programmable doses, temperature, and standby capability
- The standard version with aluminium heat exchanger and GHA cartridge

AVAILABLE VERSIONS

SEMI-AUTOMATIC POD
AUTOMATIC POD

OPTIONALS

- GHA VERSION (*black color; other colors: minimum order 50 pcs*)
- BRASS VERSION (*black color; other colors: minimum order 50 pcs*)
- 110V VERSION (*only semiautomatic*)
- CREDIT SYSTEM
- GOLD VERSION (*aluminium group; brass/GHA group: minimum order 50 pcs*)
- NICHEL VERSION (*aluminium group; brass/GHA group: minimum order 50 pcs*)
- CHROMED VERSION (*aluminium group; brass/GHA group: minimum order 50 pcs*)

On demand available in brass group version or GHA group version



The GHA treatment is the most recent and innovative patented technology with antibacterial and mould-inhibiting capabilities (bactericidal) and it inhibits the formation of limescale.

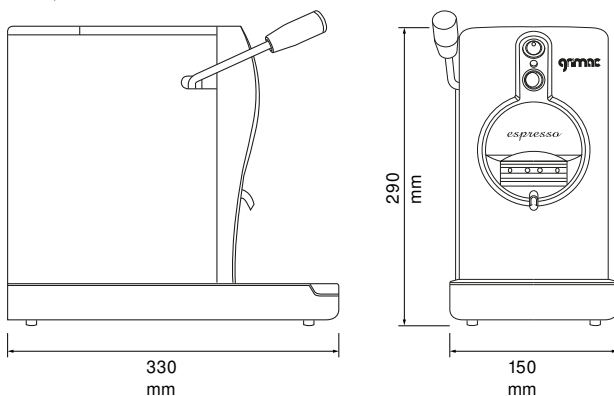

Groups	Model	Control	Electric Heater	Voltage	Boiler	Weight
1	TUBE	S	400 W	220 - 240 V 50/60 Hz	2 L	4,5 kg
1	TUBE	A	400 W	220 - 240 V 50/60 Hz	2 L	5,2 kg